



Contents	Page
Introduction	101
RE 1 & RE 2 Series - Stripping Systems	102
RE 3/RE 4 & RE 5 Series - Stripping Systems	103
KS Series - Cable End Stripper	104
KP Series - Cable Peeler	104
KN Series - Conical Cutter	105
LM D Series - Length Measuring Units	105

# Cable Stripping & Measurement

Techna offer a range of cable stripping tools suitable for both manual operations and driven systems. With a variety of systems covering diameters from 6mm to 100mm, and with models suitable for the removal of cross-linked polymer coatings as well as PVC and other non cross-linked coverings we offer solutions to virtually any stripping requirement.

Our range also includes manual cable-end strippers and peelers and conical cutters for cable end preparation.

To complement our stripping tools we offer length measuring units suitable for a range of diameters up to 160mm.

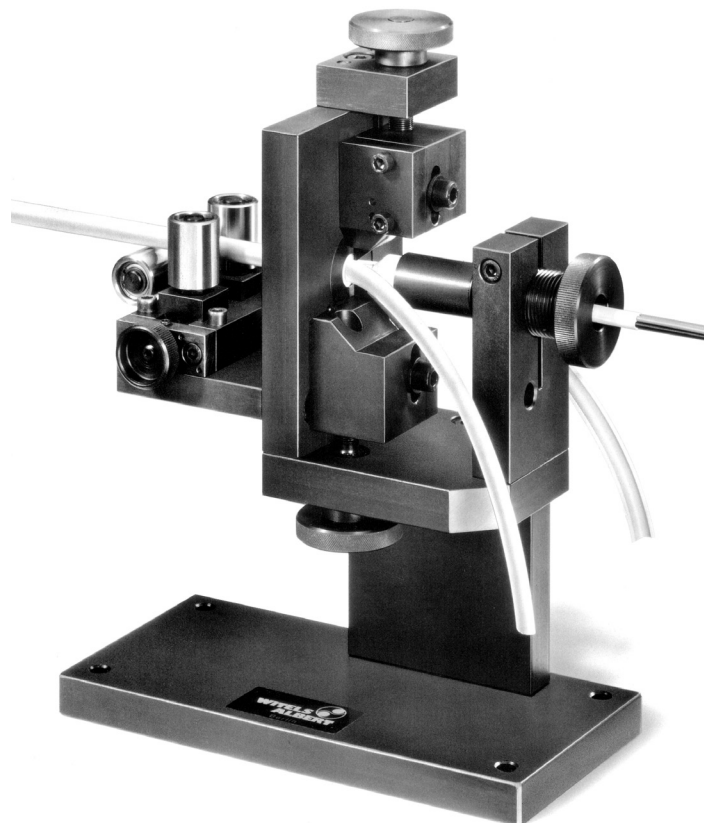

## RE 1 - Cable Stripping System

For PVC and non cross-linked cable coverings.

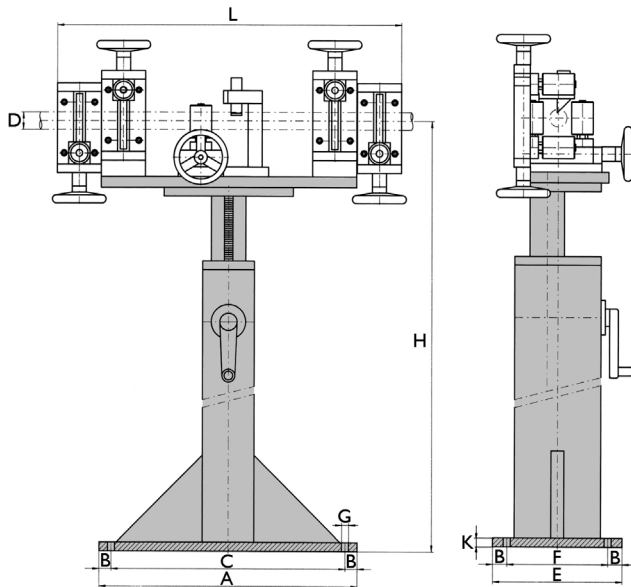
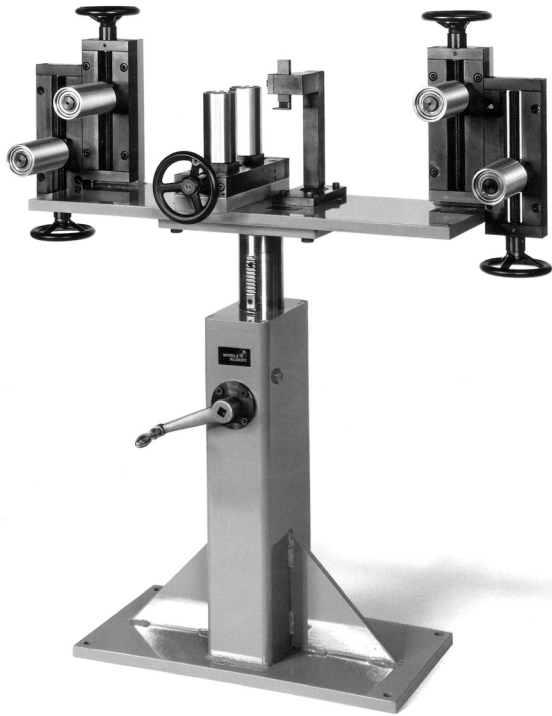

RE 1	Wire Diameter Ranges (mm) $\phi$
mm	30 - 100
Order Ref.	RE 1
A	600
B	25
C	550
D	100
E	300
F	250
G	17
H	1000 $\pm$ 100
K	20
L	800
Kg	194

## RE 2 - Cable Stripping System

For cross-linked cable coverings.

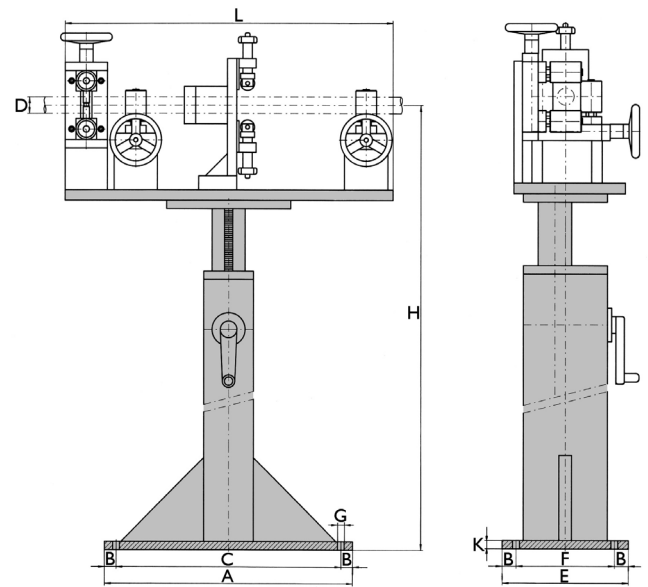

RE 2	Wire Diameter Ranges (mm) $\phi$
mm	30 - 100
Order Ref.	RE 1 RE 2
A	600
B	25
C	550
D	100
E	300
F	250
G	17
H	1000 $\pm$ 100
K	20
L	800
Kg	200

## RE 3/RE 4 - Cable Stripping System

For continuous stripping of PVC and non cross-linked coverings.

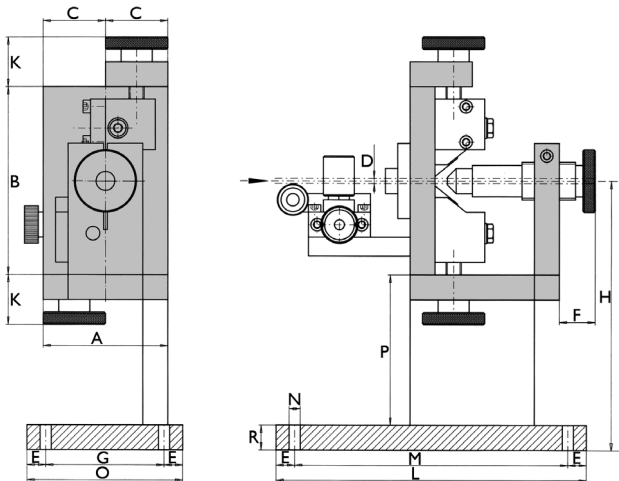
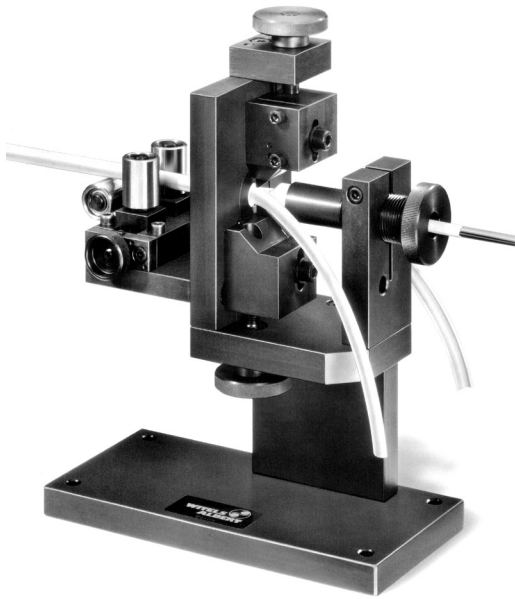

RE 3 / RE 4 mm	Wire Diameter Ranges (mm) $\phi$	
	6 - 12	13 - 30
<b>Order Ref.</b>	<b>RE 3</b>	<b>RE 4</b>
A	100	100
B	150	160
C	50	50
D	12	30
E	15	15
F	40	40
G	95	95
H	215	220
K	40	40
L	250	250
M	220	220
N	9	9
O	125	125
P	120	120
R	20	20
Kg	16	17

## RE 5 - Cable Stripping System

For continuous stripping of cross-linked and non cross-linked coverings.

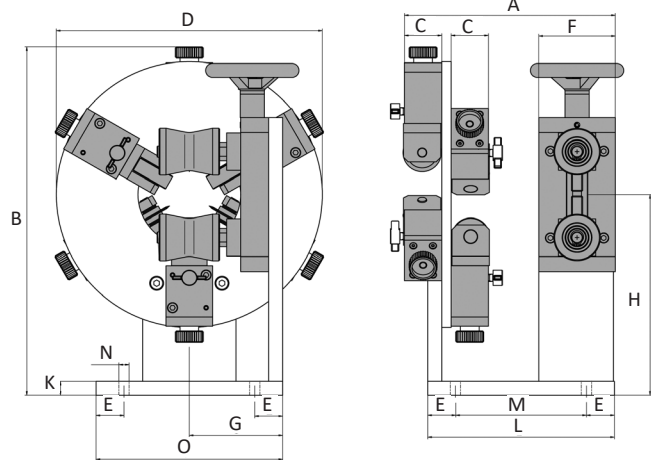
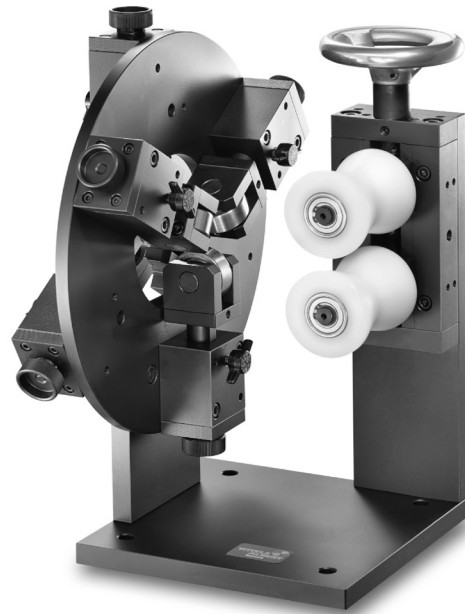

RE 5 mm	Wire Diameter Ranges (mm) $\phi$
	10.0 - 50.0
<b>Order Ref.</b>	<b>RE5</b>
A	226
B	373
C	40
D	285
E	30
F	82
G	100
H	215
K	15
L	200
M	140
N	11
O	200
Kg	25.5

## KS - Cable End Stripper

For manual stripping of PVC and non cross-linked coverings.

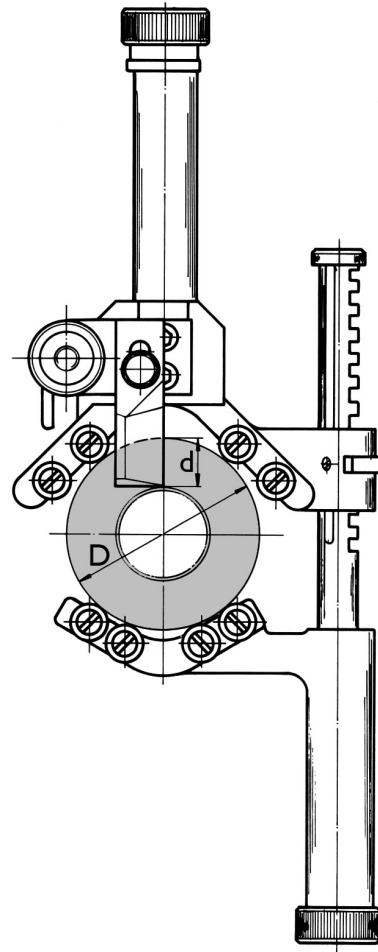

KS	Wire Diameter Ranges (mm) $\phi$		
mm	20 - 40	40 - 80	60 - 100
Order Ref.	KS 40	KS 80	KS 100
D	20 - 40	40 - 80	60 - 100
d	0 - 20	0 - 25	0 - 25
Kg	2.1	3.3	3.3

## KP - Cable Peeler

Manual Cable Peeler for PVC and non cross-linked coverings.

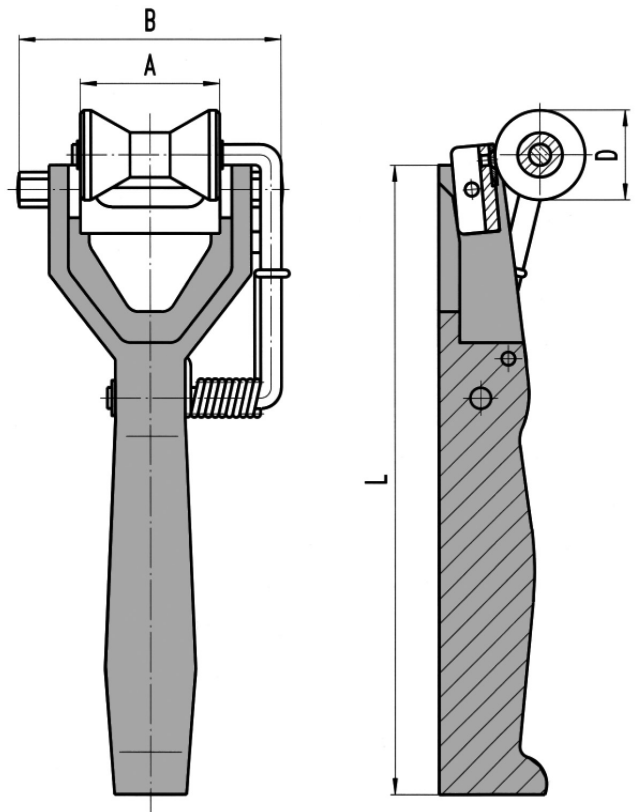

For diameters up to 40mm.

KP	Wire Diameter Ranges (mm) $\phi$
mm	0 - 40
Order Ref.	KP 40
A	40
B	76
D	26
L	181
Kg	0.35

## KN - Conical Cutter

For conical end cutting of PVC and non cross-linked coverings.

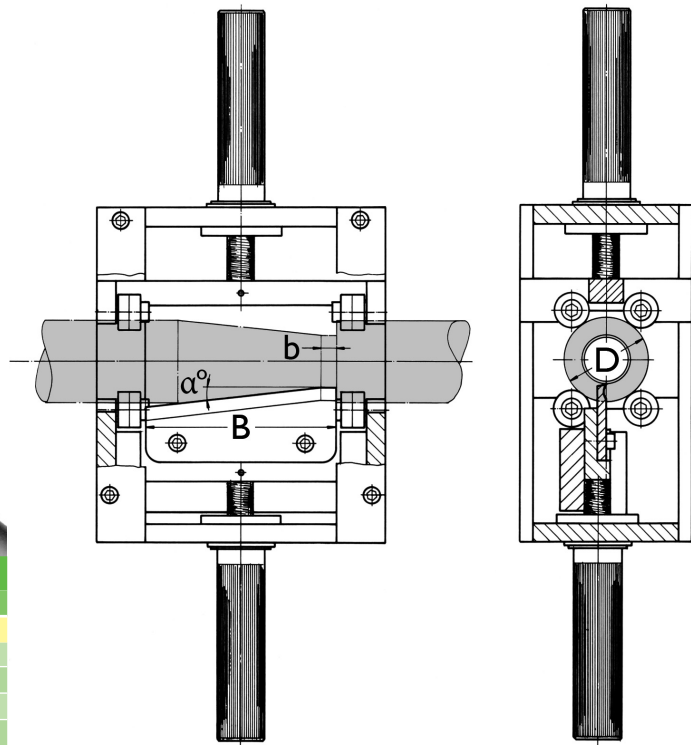
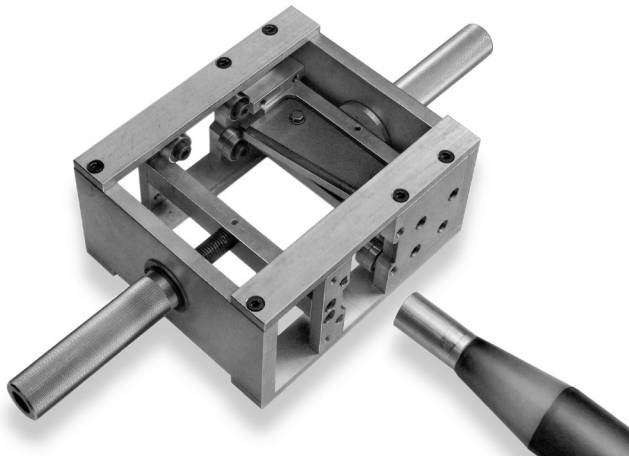

KN	Wire Diameter Ranges (mm) $\phi$		
mm	20 - 40	40 - 80	80 - 100
Order Ref.	<b>KN 40</b>	<b>KN 80</b>	<b>KN 100</b>
B	60	120	120
b	4	12	12
$\alpha$ [°]	8	14	14
D	20 - 40	40 - 80	80 - 100

## LM D - Length Measuring Unit

Material passes through the large diameter rolls fitted to an encoder to provide a digital output of length.

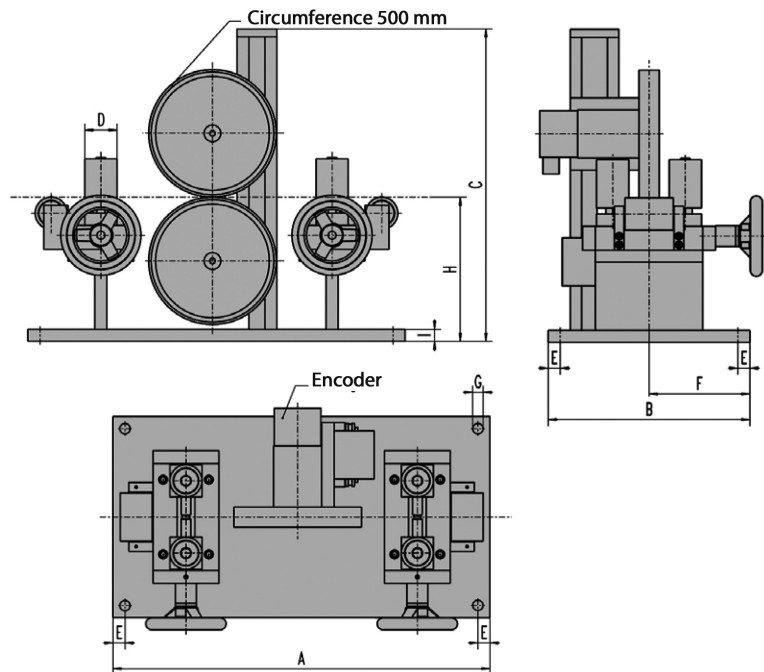

LM D	Wire Diameter Ranges (mm) $\phi$			
mm	0.5 - 12	6 - 50	10 - 100	50 - 160
Order Ref.	<b>LM 12 D</b>	<b>LM 50 D</b>	<b>LM 100 D</b>	<b>LM 160 D</b>
A	320	470	540	660
B	180	250	300	400
C	340	390	445	495
D	25	40	60	80
E	15	15	20	20
F	90	125	150	200
G	13	13	17	17
H	180	180	185	185
I	15	15	20	20
Kg	12	20	38	82